

## Data Sheet

### **HE-Series Analog**

Magnetostrictive Linear Position Sensors

- Linearity  $< \pm 1$  mm
- Resolution  $< 0.2$  mm
- Compact Robust Design
- Stroke lengths from 100...500 mm



## MEASURING TECHNOLOGY

Temposonics linear position sensors utilizing Hall Effect technology are able to determine position with a high level of repeatability and robustness. The sensors consist of a conducting sensing element, a position magnet and supporting electronics. The sensing element is powered by an electric current. The position magnet is attached to the object in motion for the given application. The magnet's field component perpendicular to the sensing element creates a measurable voltage that is proportional to the strength of the magnetic field that is converted into a linear position measurement. Since the output from the sensor corresponds to an absolute position, rather than a relative value, recalibration is not required.

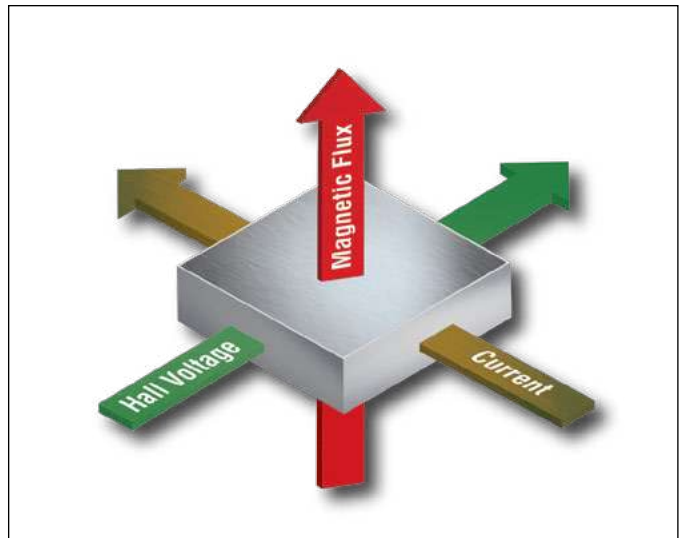

Fig. 1: Hall Effect principle

## HE SENSOR

The Temposonics® HE-Series sensors utilizing Hall Effect technology are specifically designed for direct stroke measurement in hydraulic cylinders. With virtually no dead zone, tight pin to pin measurements can be achieved. HE-Series sensors can be fully sealed and embedded in a cylinder which provides excellent protection against the environment and EMI and ensures a long operating life. With six different mounting styles, the HE-Series sensors can be installed externally from the head side or internally from the rod side of the cylinder depending on the cylinder design. An optional Temposonics M12 connector system ensures protection to IP69K. Signal output: analog.

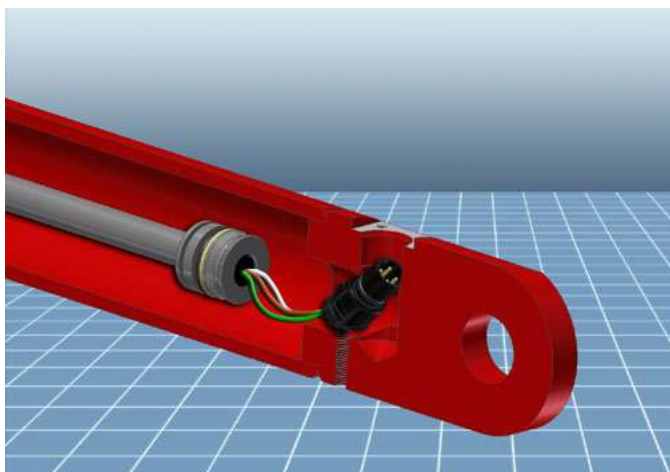

Fig. 2: Typical application – Sprayer

## M12 CONNECTOR SYSTEM (TYPE "D")

### Temposonics M12 connector system

The M12 connector system meets the highest protection requirements important for a harsh environment in mobile hydraulic applications. Ingress Protection rating of IP69K (dust proof and high pressure water cleaning) with a mating connector.



- 1 The HE-Series (type "D") is delivered by Temposonics together with the connector system:  
The connector insert carrier is already connected to the sensor conductors, i.e. no soldering and no color or connection mistake.

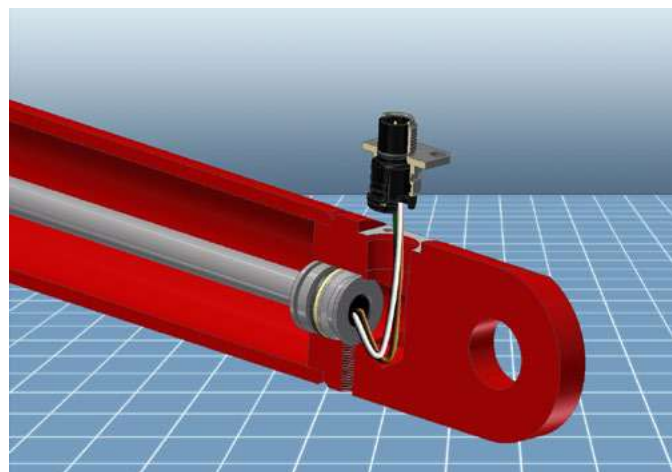

- 2 The connector insert is taken out of the cylinder through a bore hole. The flange can easily be clicked in position from outside.

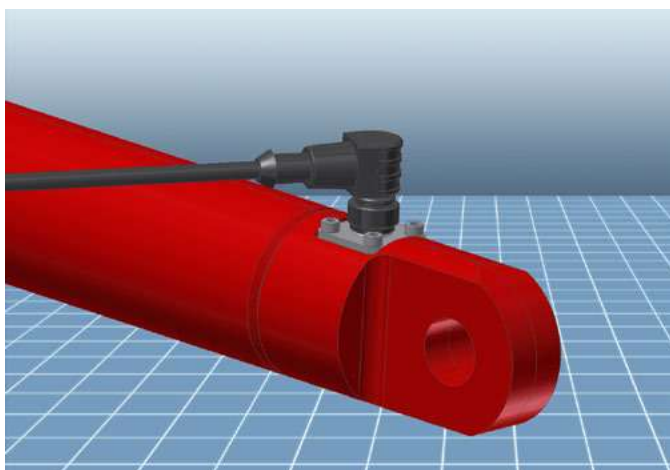

- 3 Four standard screws must be tightened to mount the connector system on the cylinder. In case of using angled type connectors the connector insert can be rotated inside the flange in 45° steps.



- 4 With a corresponding mating plug the connector system fulfills a ingress protection rating of IP69K.

- Safe and easy installation.
- No soldering or crimping of connecting leads.

## TECHNICAL DRAWING

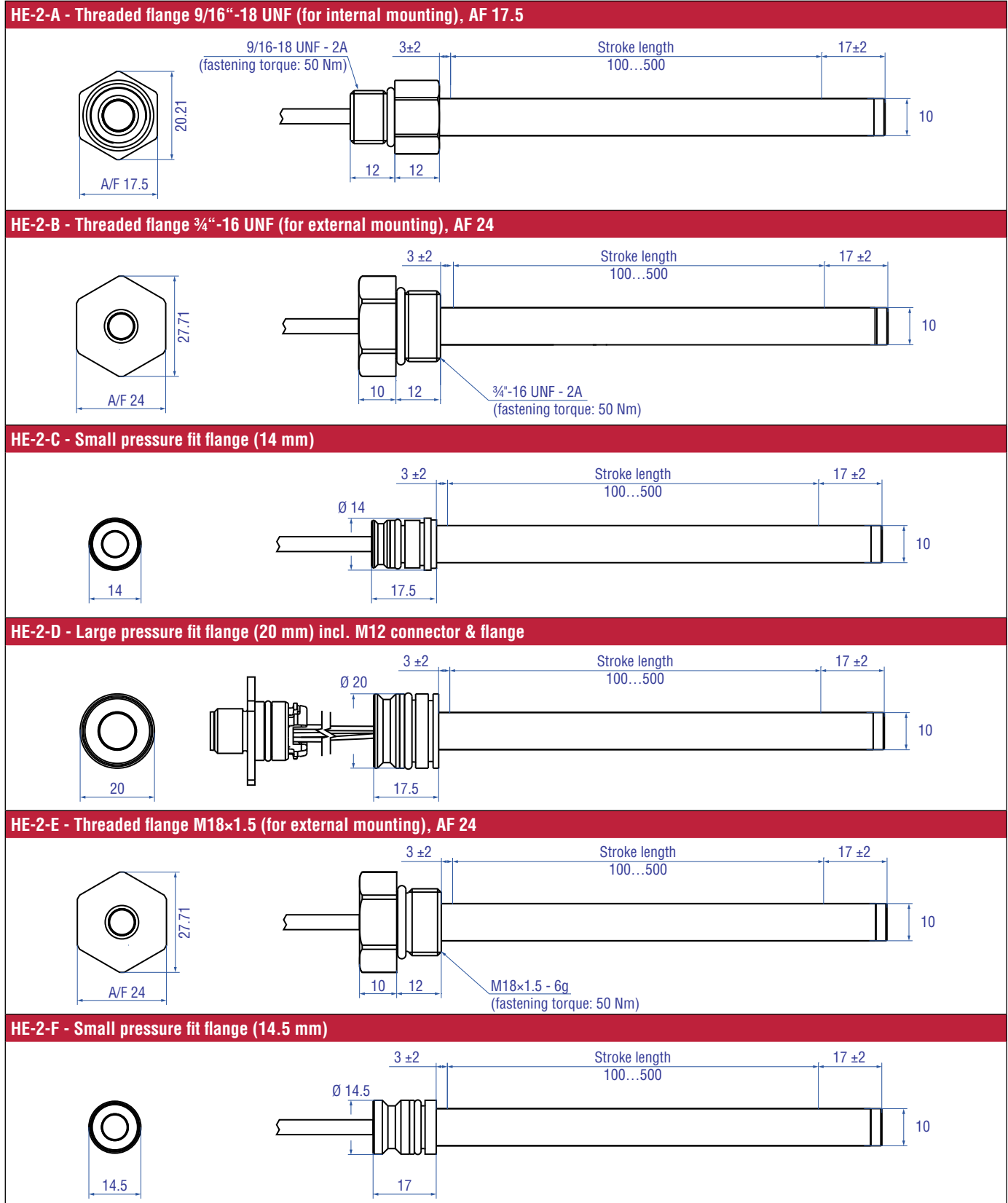

Fig. 3: HE-Series sensors types

Controlling design dimensions are in millimeters

**CONNECTOR WIRING**

M12 connector				
	Pin	E	G	H
	1	not connected	VDC	VDC
	2	VDC	not connected	SIG
	3	GND	GND	GND
	4	SIG	SIG	not connected

Fig. 4: Pin assignment for M12 connector

Cable / Wires		
	Cable	A
	BN	VDC
	WH	GND
	GN	SIG

Fig. 5: Cable assignment

DTM06-3S		
	Pin	Function
	A	VDC
	B	GND
	C	SIG

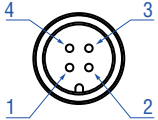
Fig. 6: Pin assignment of DTM06 connector (Part no. 254 597)

DT04-3P		
	Pin	Function
	A	VDC
	B	GND
	C	SIG

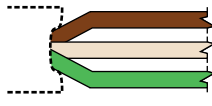
Fig. 7: Pin assignment of DT04 connector (Part no. 254 600)

**ELECTRICAL INSTALLATION**

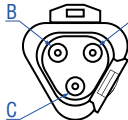
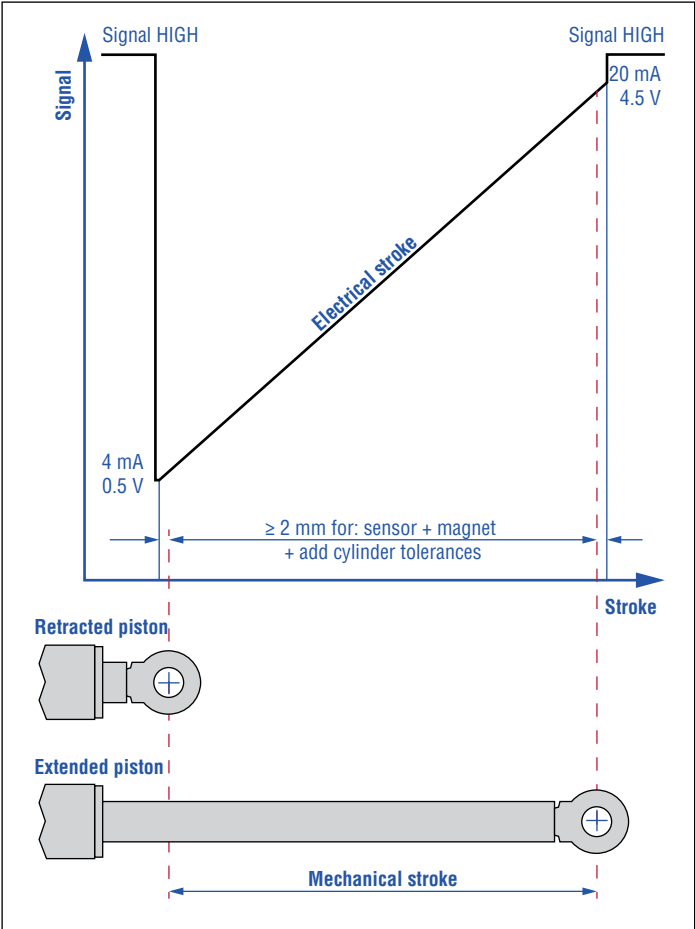

Fig. 8: Electrical installation

## MECHANICAL INSTALLATION

### In-Cylinder assembly (e.g. with flange type "D")

The robust linear position sensor HE is designed for direct stroke measurement in hydraulic cylinders.

The position sensor can be installed from the head side or the rod side of the cylinder depending on the cylinder design.

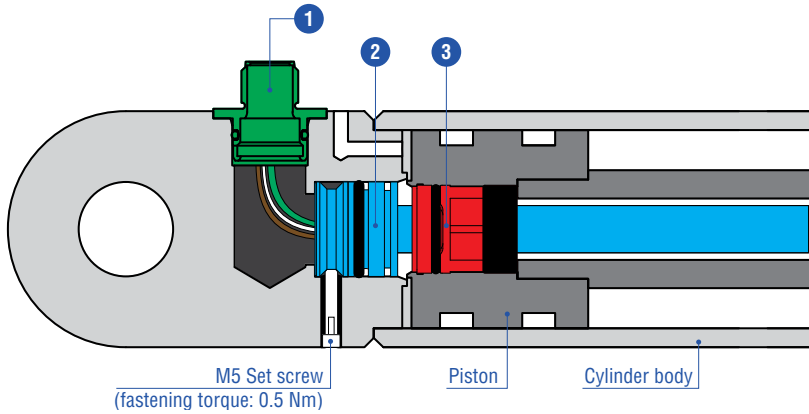

#### 1 M12 connector

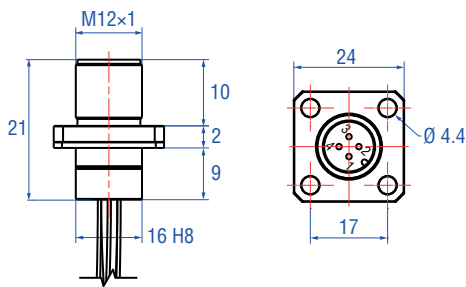

#### 3 Position magnet

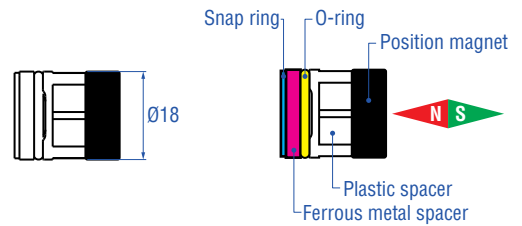

#### 2 HE sensor (e.g. with flange type "D")

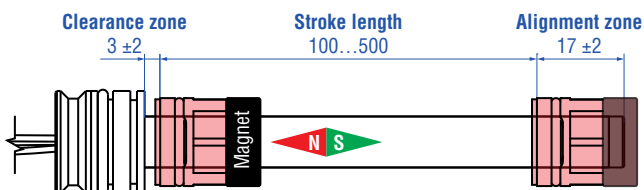

#### NOTICE

- The sequence of snap ring, spacer, O-ring, plastic spacer and position magnet must be respected
- Orient the polarity of the position magnet as shown (North toward sensor flange)
- Assemble the sensor with the delivered position magnet, do not mix the sensor with other magnets

Fig. 9: Example of In-Cylinder assembly

Controlling design dimensions are in millimeters

TECHNICAL DRAWING

Type A (internal mounting (threaded flange 9/16"-18 UNF))

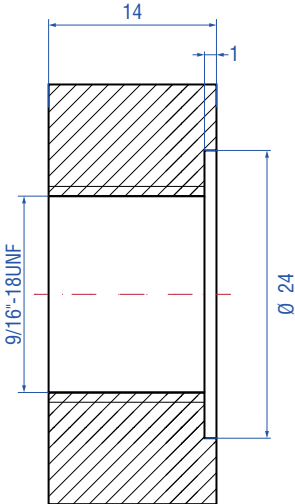

Type B (external mounting (thread flange 3/4"-16 UNF))

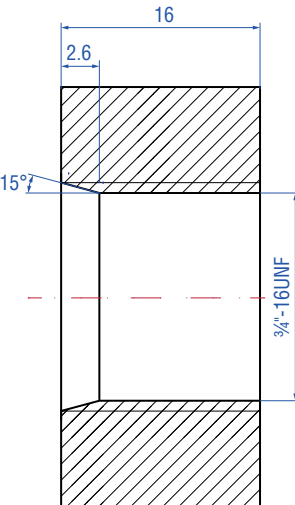
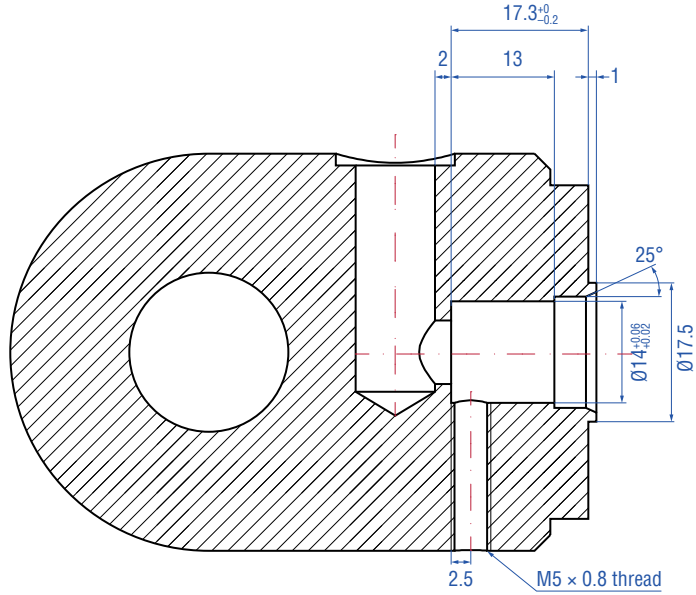

Fig. 10: Flange types "A" and "B"

Controlling design dimensions are in millimeters

**Type C (pressure fit flange Ø 14 mm)**



**Type D (pressure fit flange Ø 20 mm)**

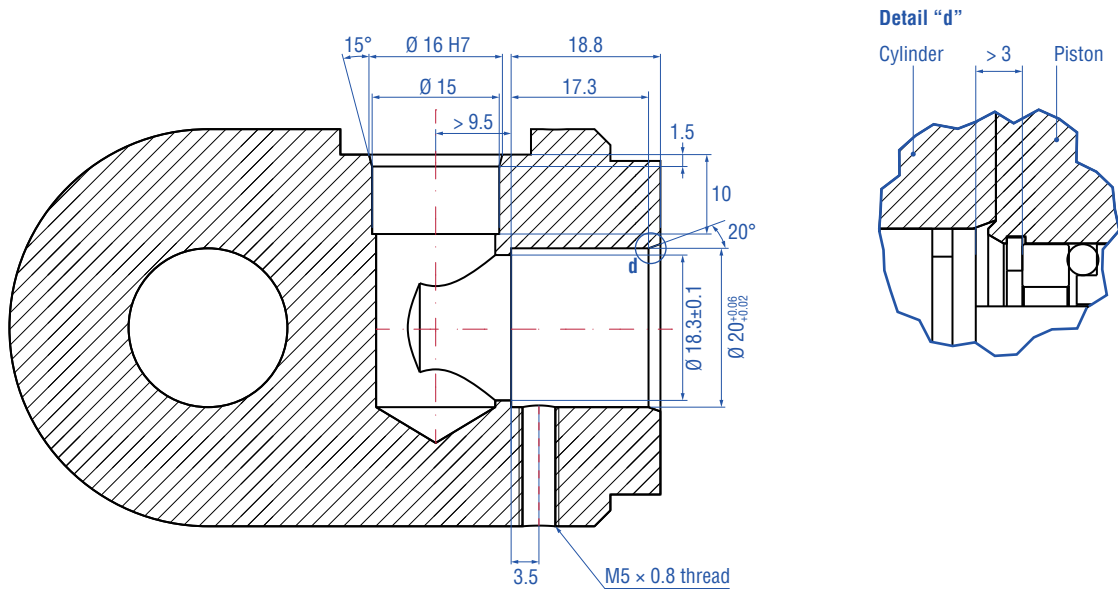
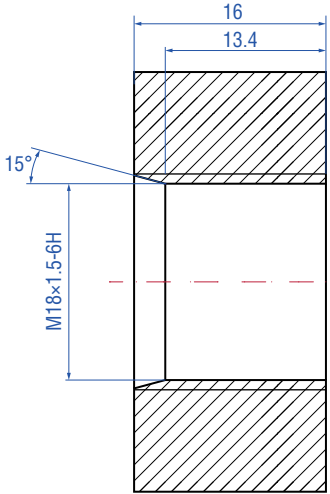

Fig. 11: Flange types "C" and "D"

Controlling design dimensions are in millimeters



Type E (external mounting (threaded flange M18×1.5))



Type F (pressure fit flange Ø 14.5 mm)

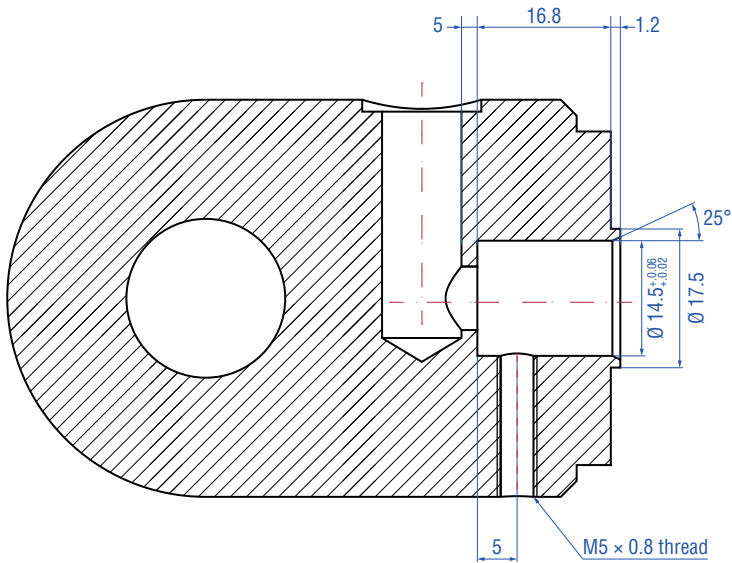

Fig. 12: Flange types “E” and “F”

Controlling design dimensions are in millimeters

## Piston rod drilling – Magnet embedding

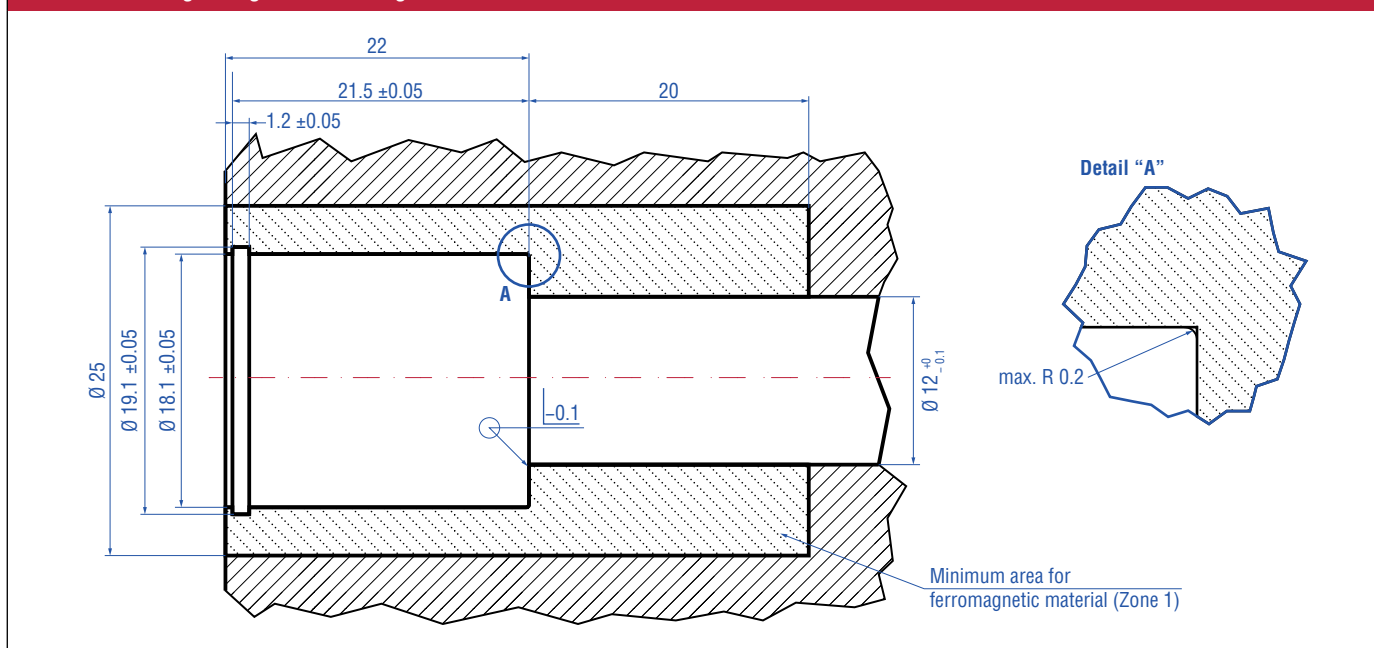

Fig. 13: Dimensions of piston drilling

### NOTICE

Minimum area of ferromagnetic material in the piston

## TECHNICAL DATA

Output	
Voltage	0.5...4.5 VDC
Current	4...20 mA
Measured value	Position
Measurement parameters	
Resolution	< 0.2 mm
Linearity	< ±1 mm typ.
Repeatability	< ±0.5 mm typ.
Hysteresis	< ±0.5 mm typ.
Operating conditions	
Operating temperature	-40...+85 °C
Humidity	95 % @ 55 °C (DIN EN 60068-2-30 )
Ingress protection	M12 connector: IP69K plugged with mating connector EN60529; Sensor housing: IP67 EN60529
Shock test	50 g / 10 ms up to 500 mm sensor length (single shock) / IEC 60068-2-27 100 g / 6 ms up to 180 mm sensor length (single shock) / IEC 60068-2-27
Vibration test	Random Noise Peak Acceleration 15 g <sub>rms</sub> based on DIN EN 60068-2-64 15 g / 20...2000 Hz Sinusoidal, IEC standard 60068-2-6 (resonance frequencies excluded)
EMC test	EN 61000-6-2 Radiated Immunity (industrial) EN 61000-6-4 Emissions (industrial) ISO 13766 Earth moving machinery DIN EN 13309 Construction machinery ISO 14982 Agricultural and forestry machinery The sensor meets the requirements of the EC directives and is marked with <b>CE</b>
Design / Material	
Sensor housing	Stainless steel 1.4301 (AISI 304)
Sensor rod	Stainless steel 1.4307 (AISI 304L)
Stroke length	100...500 mm
Operation pressure PN (nominal operating)	320 bar
Operation pressure Pmax	400 bar
Operation pressure Pstatic (proof pressure)	525 bar
Mechanical mounting	
Mounting position	Any
Mounting instruction	Please consult the technical drawings
Electrical connection	
Connection type	M12 male plug or cable assembly
Operating voltage	5 / 12 / 24 VDC (4.75...32 VDC) (400...500 mm 4.75...28 VDC)
Load (voltage output)	$R_L \geq 5 \text{ k}\Omega$
Load (current output)	$R_L \leq 50 \Omega$ (5 VDC), $R_L \leq 250 \Omega$ (12 VDC), $R_L \leq 500 \Omega$ (24 VDC)
Current consumption*	$\leq 530 \text{ mA}$ (5 VDC), $\leq 200 \text{ mA}$ (12 VDC), $\leq 125 \text{ mA}$ (24 VDC)
Polarity protection (GND – VDC)	Up to 32 VDC
Overvoltage protection (GND – VDC)	Up to 50 VDC

\* length dependent

## ORDER CODE

1	2	3	4	5	6	7	8	9	10	11	12	13	14	15	16	
H	E	2					M									
a		b	c	d				e			f	g	h			

### a Sensor model

H	E	Hall effect
---	---	-------------

### b Design

2	2 <sup>nd</sup> Generation
---	----------------------------

### c Flange

A	Threaded flange 9/16"-18 UNF (for internal mounting), AF 17.5
B	Threaded flange 3/4"-16 UNF (for external mounting), AF 24
C	Small pressure fit flange (14 mm)
D	Large pressure fit flange (20 mm) incl. M12 connector & flange
E	Threaded flange M18x1.5 (for external mounting), AF 24
F	Small pressure fit flange (14.5 mm)

### d Stroke length

X	X	X	M	100...500 mm (20 mm increments)
---	---	---	---	---------------------------------

### e Connection type

#### Single wires (for all flange options)

N	0	4	40 mm
N	0	6	60 mm
N	0	8	80 mm
N	1	0	100 mm
N	1	2	120 mm
N	1	4	140 mm
N	1	6	160 mm
N	1	8	180 mm
N	1	0	200 mm
N	2	2	220 mm
N	2	4	240 mm
N	2	5	250 mm

#### PUR Cable (for all flange options)

T	0	3	300 mm
T	0	5	500 mm
T	1	0	1000 mm
T	2	0	2000 mm
T	3	0	3000 mm
T	5	0	5000 mm

### f Cable / Wire / Pin termination

#### For all flange options

A	Cable / wire assignment "A"
---	-----------------------------

#### With flange option "D" (with M12 connector)

E	Pin assignment "E"
G	Pin assignment "G"
H	Pin assignment "H"

### g Operating voltage

3	+5 / 12 / 24 VDC (4.75...32 VDC)
---	----------------------------------

### h Output

V	1	2	0.5...4.5 VDC
A	0	1	4...20 mA

## DELIVERY



Position sensor with flange O-ring(s), magnet, spacer, washer, mounting clip, M12 connector with flange (optional)

Accessories have to be ordered separately.

### NOTICE

- Consider the mechanical tolerances
- Consider the minimum area of ferromagnetic material in the piston
- The sequence of snap ring, spacer, O-ring, plastic spacer and position magnet must be respected
- Orient the polarity of the position magnet (North toward sensor flange)
- Assemble the sensor with the delivered position magnet, do not mix the sensor with other magnets

## FREQUENTLY ORDERED ACCESSORIES

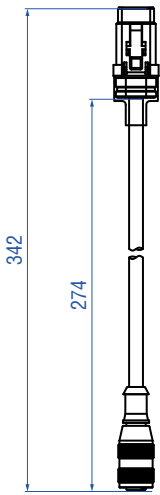
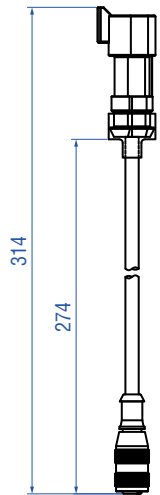
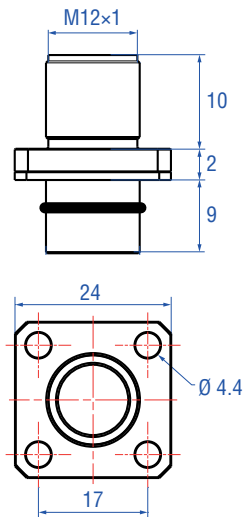
Test kit	Cord sets and adapter cables	M12 flange	
			
<p><b>Test kit Analog</b> Part no. 280 618</p>	<p><b>4 pin M12 to DTM06 connector</b> Part no. 254 597</p>	<p><b>4 pin M12 to DT04 connector</b> Part no. 254 600</p>	<p><b>M12 flange</b> Part no. 253 769</p>
<p><b>Scope of delivery:</b></p> <ul style="list-style-type: none"> <li>• Analog / PWM Tester</li> <li>• 12 VDC battery charger with adapter (adapter main plug EU, adapter main plug UK)</li> <li>• cables with M12 connector</li> <li>• cable with pigtailed wires</li> <li>• cable with Deutsch DT06-3S connector</li> <li>• carrying case</li> <li>• CD-Rom with user's guide</li> </ul>	<p>M12 connector: Brass/Nickel DT connector: DTM06 3 pin Material: PVC Jacket Cable length: 274 mm Cable Ø: 5 mm Operating temperature: -40...+105 °C</p>	<p>M12 connector: Brass/Nickel DT connector: DT04 3 pin Material: PVC Jacket Cable length: 274 mm Cable Ø: 5 mm Operating temperature: -40...+105 °C</p>	<p>Material flange: Brass nickel-plated Material O-ring: 13x1.6 NBR70</p>



# Temposonics

AN AMPHENOL COMPANY

**UNITED STATES**  
**Temposonics, LLC**  
Americas & APAC Region  
3001 Sheldon Drive  
Cary, N.C. 27513  
Phone: +1 919 677-0100  
E-mail: [info.us@temposonics.com](mailto:info.us@temposonics.com)

---

**GERMANY**  
**Temposonics**  
**GmbH & Co. KG**  
EMEA Region & India  
Auf dem Schüffel 9  
58513 Lüdenscheid  
Phone: +49 2351 9587-0  
E-mail: [info.de@temposonics.com](mailto:info.de@temposonics.com)

---

**ITALY**  
Branch Office  
Phone: +39 030 988 3819  
E-mail: [info.it@temposonics.com](mailto:info.it@temposonics.com)

---

**FRANCE**  
Branch Office  
Phone: +33 6 14 060 728  
E-mail: [info.fr@temposonics.com](mailto:info.fr@temposonics.com)

---

**UK**  
Branch Office  
Phone: +44 79 44 15 03 00  
E-mail: [info.uk@temposonics.com](mailto:info.uk@temposonics.com)

---

**SCANDINAVIA**  
Branch Office  
Phone: + 46 70 29 91 281  
E-mail: [info.sca@temposonics.com](mailto:info.sca@temposonics.com)

---

**CHINA**  
Branch Office  
Phone: +86 21 2415 1000 / 2415 1001  
E-mail: [info.cn@temposonics.com](mailto:info.cn@temposonics.com)

---

**JAPAN**  
Branch Office  
Phone: +81 3 6416 1063  
E-mail: [info.jp@temposonics.com](mailto:info.jp@temposonics.com)

---

**Document Part Number:**  
551654 Revision F (EN) 09/2018



## temposonics.com

© 2021 Temposonics, LLC – all rights reserved. Temposonics, LLC and Temposonics GmbH & Co. KG are subsidiaries of Amphenol Corporation. Except for any third party marks for which attribution is provided herein, the company names and product names used in this document may be the registered trademarks or unregistered trademarks of Temposonics, LLC or Temposonics GmbH & Co. KG. Detailed trademark ownership information is available at [www.temposonics.com/trademarkownership](http://www.temposonics.com/trademarkownership).